



12TON Jumbo
(IRON FAIRY)

AP 415

All-purpose hydraulic crane

- Maximum on-board tip height 19 metres (62 ft)
- 5 metre (16 ft 5 in)* lattice Swingaway offsettable to 10°
- Maximum speed 55 kph (34 mph)
- Optional *four wheel steer
- Over 8 tonnes (18,000 lb) 'pick and carry' capacity

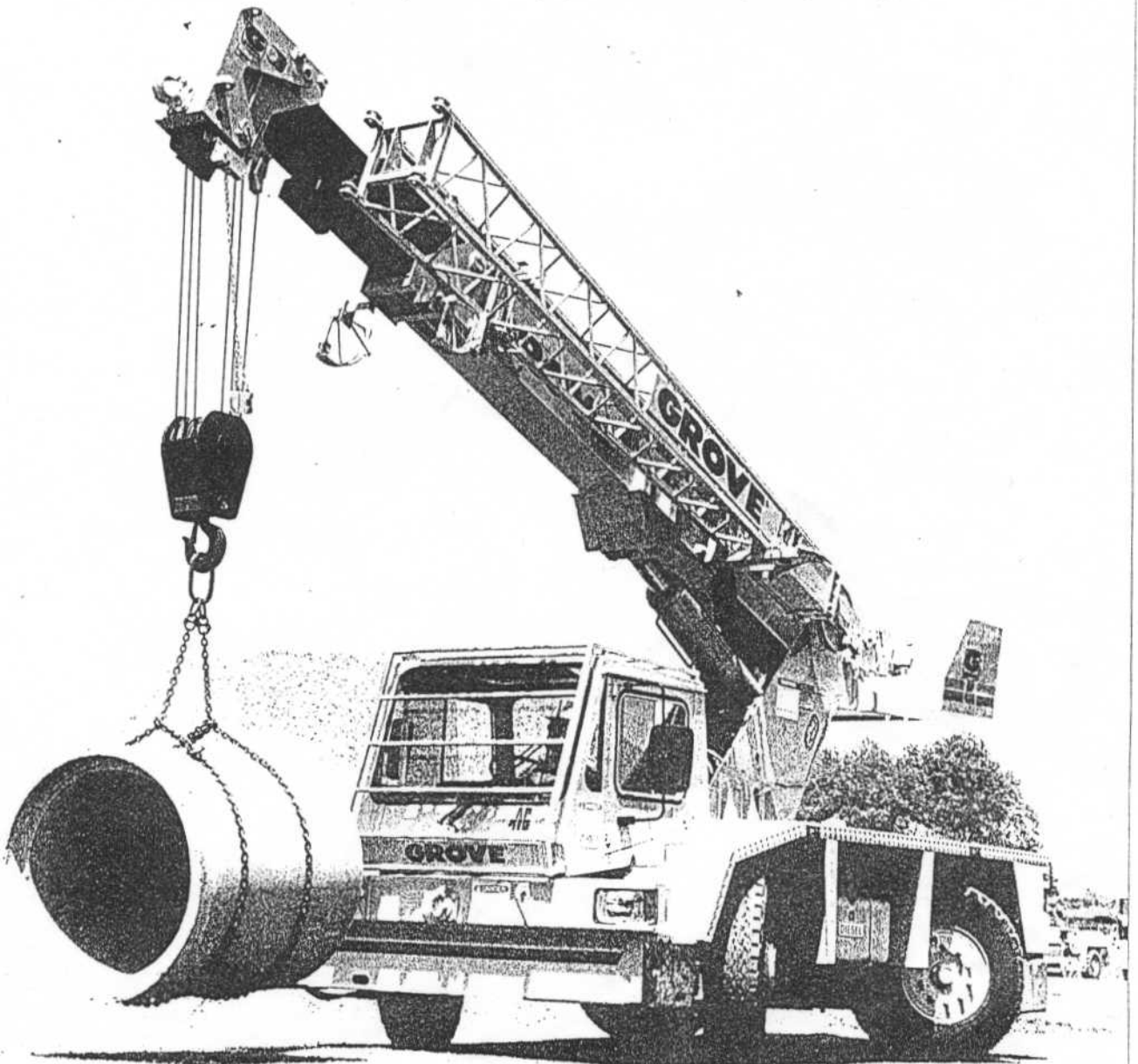

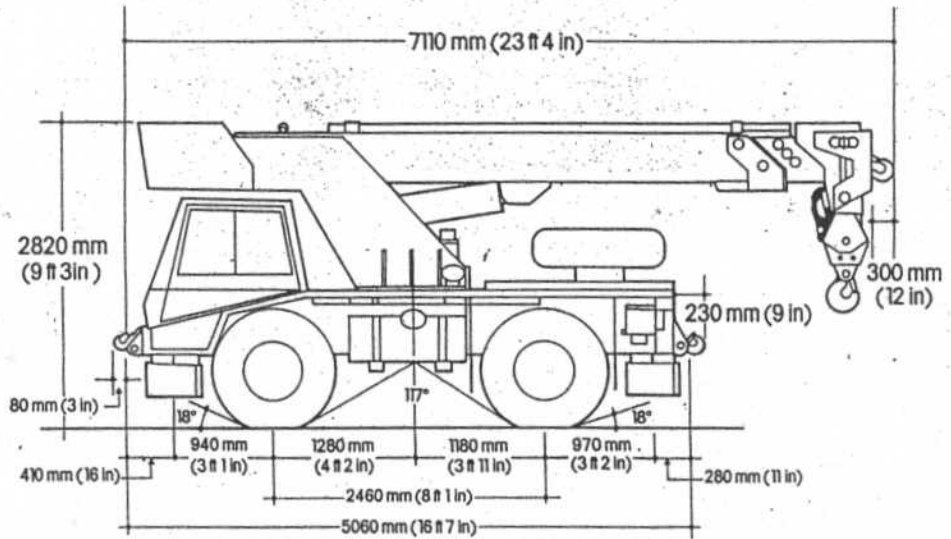

Kerb to kerb outer radius
 Front wheel steer 5800 mm (19 ft)
 Rear wheel steer 5500 mm (18 ft 1 in)
 4-wheel steer 4000 mm (13 ft 1 in)

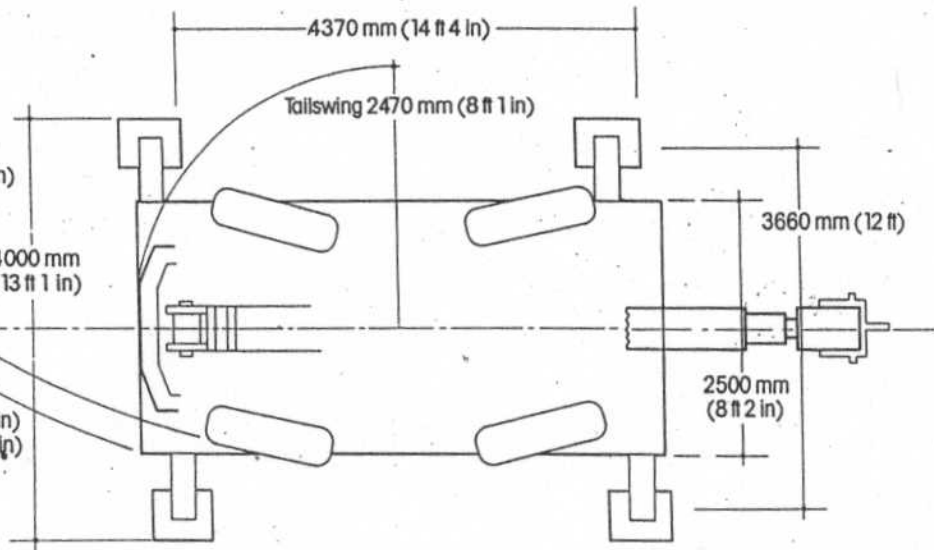

Wall to wall radius
 Front wheel steer 6500 mm (21 ft 4 in)
 Rear wheel steer 6300 mm (20 ft 8 in)
 4-wheel steer 4600 mm (15 ft 1 in)

Dimensions refer to machine with standard tyres



Constant improvement and engineering progress make it necessary that the company reserves the right to make specification, equipment and price changes without notice. Illustrations shown may include optional equipment and accessories and may not include all standard equipment. Optional equipment is designated by (*) in specifications folder.

Harefield, Uxbridge, Middlesex, UB9 6QG; England
 Telephone: Harefield (089 582) 3777
 Telex: 21619 CRANES G

Specification No GC/415/1185 Printed in England CSA 9193

LIFTING CAPACITIES — 3 SECTION BOOM

5.5 m to 9.0 m two piece boom plus 3.5 m PPE sect.

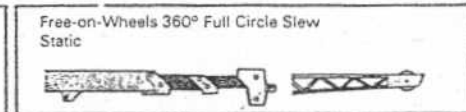
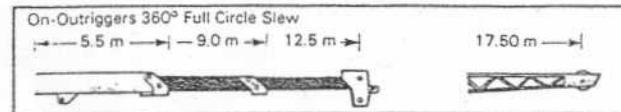

Radius in Metres	5.5 m Fully Retracted	5.5 m to 9.0 m (Manual Retracted)	9.0 m to 12.5 m (Manual Extended)	5.5 m to 12.5 m Boom Fully Telescoping plus 5.0 m Lattice Extension at			
				0° Offset		10° Offset	
				L°	Load	L°	Load
2.50 m	12.00						
2.75 m	12.00	10.50					
3.00 m	12.00	10.00					
3.50 m	10.23	9.35					
4.00 m		8.75					
4.50 m		8.28	4.80				
5.00 m		7.10	4.50				
6.00 m		5.16	4.05				
7.00 m		3.94	3.70	65°	2.45	65°	2.00@7.5
8.00 m			3.40	61°	2.24	63°	1.90
9.00 m			2.80	57°	2.10	59°	1.80
10.00 m			2.35	53°	1.95	55°	1.70
12.00 m			2.15@10.5	43°	1.60	45°	1.50
14.00 m				31°	1.26	33°	1.20
15.50 m				17°	1.09	19°	0.90

Radius in Metres	5.5 m to 9.0 m (Manual Retracted)	9.0 m to 12.5 m (Manual Extended)	5.5 m to 12.5 m Boom Fully Telescoping plus 5.0 m Lattice Extension at			
			0° Offset		10° Offset	
			L°	Load	L°	Load
2.50 m	8.00					
2.75 m	7.15					
3.00 m	6.58					
3.50 m	5.64					
4.00 m	4.68					
4.50 m	3.85	3.85				
5.00 m	3.23	3.23				
6.00 m	2.37	2.37				
7.00 m	1.79	1.79	65°	2.10	65°	1.90@7.5
8.00 m		1.44	61°	1.69	63°	1.70
9.00 m		1.13	57°	1.37	59°	1.40
10.00 m		0.88	53°	1.13	55°	1.16
12.00 m		0.78@10.5	43°	0.77	45°	0.79
14.00 m			31°	0.52	33°	0.54

Radius in Metres	5.5 m to 9.0 m (Manual Retracted)	9.0 m to 12.5 m (Manual Extended)	5.5 m to 12.5 m Boom Fully Telescoping plus 5.0 m Lattice Extension at			
			0° Offset		10° Offset	
			L°	Load	L°	Load
2.50 m	8.47					
2.75 m	7.82					
3.00 m	7.26					
3.50 m	6.30					
4.00 m	5.67					
4.50 m	5.04	4.65				
5.00 m	4.35	4.35				
6.00 m	3.20	3.20				
7.00 m	2.45	2.45	65°	2.45	65°	1.90@7.5
8.00 m		1.98	61°	2.24	63°	1.80
9.00 m		1.59	57°	1.84	59°	1.65
10.00 m		1.29	53°	1.54	55°	1.50
12.00 m		1.16@10.5	43°	1.09	45°	1.19
14.00 m			31°	0.79	33°	0.86
15.50 m			17°	0.62	19°	0.67

- IMPORTANT NOTES**
- Capacities are in accordance with DIN 15019 Part 2 1979 and clause 11 — Stability of BS 1757: 1981 — Power-driven mobile cranes with wind forces to tables 2 (a) and 3 (a) of BS 2573: Part 1: 1977 — Permissible stresses in crane and design rules — Structures.
 - Capacities above the thick line are based on factors other than stability and for this reason crane tipping must not be relied upon as a guide to the capacity limitation.
 - The weight of the hookblock, slings and all similarly used load handling devices must be added to the weight of the load.
 - Capacities quoted are based on freely suspended loads, with the four telescopic outriggers fully extended and down so that tyres are raised clear of the ground with the machine accurately levelled on firm and uniformly supported surfaces, or when operating free-on-wheels with the machine standing on a firm, level and uniformly supporting surface with tyres inflated to the correct pressure.
 - Practical safe working loads are dependent on the supporting surface, wind and other factors affecting stability, hazardous surroundings, experience of personnel and proper handling of the load, all of which must be taken into account by the operator.
 - Angle based capacities are determined by laden boom angles given and not by radius. Radii quoted refer only to fully extended booms.
 - When the lattice extension is fitted in the operating position, main boom capacities must be reduced by 0.62 tonne.
 - When a safe load indicator is specified, certain duties may be modified to compensate for indicator characteristics.
 - This crane is designed and manufactured for high load derricking capability. It is safe to attempt to derrick any load.

LIFTING CAPACITIES — 3 SECTION BOOM

5.5 m to 12.5 m fully powered boom



Radius in Metres	5.5 m Fully Retracted	5.5 m to 9.0 m (Fully Powered Boom)	9.0 m to 12.5 m (Fully Powered Boom)	5.5 m to 12.5 m Boom Fully Telescoping plus 5.0 m Lattice Extension at			
				0° Offset		10° Offset	
				L°	Load	L°	Load
2.50 m	12.00						
2.75 m	12.00	10.25					
3.00 m	12.00	9.75					
3.50 m	10.23	9.35					
4.00 m		8.75					
4.50 m		8.35	5.10				
5.00 m		7.14	4.80				
6.00 m		5.16	4.30				
7.00 m		3.94	3.85	65°	2.45	65°	2.00@7.5
8.00 m			3.19	61°	2.24	63°	1.90
9.00 m			2.59	57°	2.10	59°	1.80
10.00 m			2.14	53°	1.95	55°	1.70
12.00 m			1.95@10.5	43°	1.60	45°	1.50
14.00 m				31°	1.26	33°	1.20
15.50 m				17°	1.09	19°	0.90

Radius in Metres	5.5 m to 9.0 m (Fully Powered Boom)	9.0 m to 12.5 m (Fully Powered Boom)	5.5 m to 12.5 m Boom Fully Telescoping plus 5.0 m Lattice Extension at			
			0° Offset		10° Offset	
			L°	Load	L°	Load
2.50 m	8.00					
2.75 m	7.15					
3.00 m	6.58					
3.50 m	5.64					
4.00 m	4.68					
4.50 m	3.85	3.85				
5.00 m	3.23	3.23				
6.00 m	2.37	2.37				
7.00 m	1.79	1.79	65°	2.10	65°	1.50@7.5
8.00 m		1.44	61°	1.69	63°	1.70
9.00 m		1.13	57°	1.37	59°	1.40
10.00 m		0.88	53°	1.13	55°	1.16
12.00 m		0.78@10.5	43°	0.77	45°	0.79
14.00 m			31°	0.52	33°	0.54

Radius in Metres	5.5 m to 9.0 m (Fully Powered Boom)	9.0 m to 12.5 m (Fully Powered Boom)	5.5 m to 12.5 m Boom Fully Telescoping plus 5.0 m Lattice Extension at			
			0° Offset		10° Offset	
			L°	Load	L°	Load
2.50 m	8.47					
2.75 m	7.82					
3.00 m	7.26					
3.50 m	6.30					
4.00 m	5.67					
4.50 m	5.04	4.65				
5.00 m	4.35	4.35				
6.00 m	3.20	3.20				
7.00 m	2.45	2.45	65°	2.45	65°	1.90@7.5
8.00 m		1.98	61°	2.24	63°	1.80
9.00 m		1.59	57°	1.84	59°	1.65
10.00 m		1.29	53°	1.54	55°	1.50
12.00 m		1.16@10.5	43°	1.09	45°	1.19
14.00 m			31°	0.79	33°	0.86
15.50 m			17°	0.62	19°	0.67

- FREE ON WHEELS**
- Capacities quoted are based on freely suspended loads with the tyres inflated to their correct pressures and axle locks engaged.
 - Free over front capacities must only be lifted within a maximum slewing angle of 2½° either side of crane centre line and are valid only up to a maximum travel speed of 5 km/h.
 - The machine must be level on firm and uniformly supporting surfaces.

Hookblock Capacities and Weights — Tonnes

Number of Falls	5	4	3	2	1
Permissible Load	12.00	10.00	7.60	5.10	2.60
Weight of Hookblock	0.18	0.18	0.18	0.18	0.10

Carrier specifications

Frame	High strength steel with integral outrigger housings. Front and rear towing brackets.
Outrigger system	Single stage, hydraulic telescopic curved beam outriggers with holding valves. Steel fabricated outrigger floats, 340 mm (13 in) width.
Outrigger controls	Situated in operator's cab with level bubble adjacent to controls.
Engine	Perkins P6.354.4, six-cylinder, naturally-aspirated, water-cooled diesel. 5.8 litre, 89 kw (119 bhp) at 2500 rpm, maximum torque 400 Nm (295 lb ft) at 1400 rpm.
Fuel tank capacity	127 litres (33.50 US gallons).
Electrical system	12 v including starting.
Drive	4 × 2
Steering	Mechanical, power assisted front axle steering controlled by steering wheel. Optional *four wheel independent steering with rear axle controlled by switch, hydraulically powered to provide co-ordinated or crab steering modes. Lockout for rear axle when centralised.
Transmission	Full synchromesh gearbox with five forward and one reverse speed.
Axles	Front: Drive-steer with planetary hub reduction. Rear: Non drive, non steer. Optional *steer.
Suspension	Front: Solidly mounted to chassis. Rear: Taper-leaf spring.
Brakes	Dual-line air system operating on all wheels. Spring applied air-released park brake acting on front wheels.
Tyres	12.00 × 20-20 PR highway radials all-round. Tyre inflation kit.
Lights	Full lighting including side, head, tail, braking, directional and hazard warning lights.
Cab	One-man design, steel fabricated, central drive, fitted with safety glass. Full travel and crane controls including outriggers and full instrumentation.

Maximum speed 55 kph (34 mph).

Gross vehicle weight and axle loads
 Axle 1: 9190 kg (20,260 lb)
 Axle 2: 6860 kg (15,123 lb)
 GVW: 16,050 kg (35,383 lb)

Above weights for AP 415 to standard specification plus 5.00 m (16 ft 5 in)
 *Swingaway.

Miscellaneous equipment Full aluminium non-slip decking, maintenance tool kit and rear view mirrors.

Optional *equipment

Superstructure
 * Hookblocks
 * Hoist-drum rotation indicator
 * Base boom section mounted floodlight

Carrier
 * Electric skylight wiper
 * Towing hook(s)
 * Spotlight (360°)
 * Spare wheel and tyre
 * Spare wheel stowage
 * Cab load guard(s)

* Indicates optional item.

Superstructure specifications

Boom	5.50 to 12.50 m (18 ft 1 in to 41 ft) three-section full-power synchronised boom, with single lever control. Telescopic sections slide on adjustable and replaceable Nylatron pads. Maximum tip height 14 m (46 ft).
Optional *Swingaway	5.00 m (16 ft 5 in) lattice Swingaway extension which can be offset 0° or 10°. Slows alongside boom when not in use. Maximum tip height 19 m (62 ft).
Boom nose	Three sheaves mounted on heavy duty roller bearings. Removable pin-type rope guards.
Optional *searcher hook	4000 kg (8800 lb) capacity, boom nose mounted.
Boom elevation	One double-acting hydraulic cylinder with integral holding valve provides elevation from 0° to 65°.
Load-moment indicator and anti-two block system	Audio visual type warning with control lever lockout.
Swing	Double row ball-bearing swing circle with 360° continuous rotation. Spring-applied, hydraulically released disc brake. Plunger-type two position house lock. Maximum speed 2.45 rpm.
Counterweight	Fixed position, 3200 kg (7055 lb).

HYDRAULIC SYSTEM

Pumps	Two gear type pumps, combined capacity 194 litres/minute (51 US gallons/minute). Maximum pressure 211 kg/cm ² (3000 PSI).
Valves	Precision, four-way, double-acting control valves.
Filters	Two delivery line filters with by-pass protection and indicator.
Reservoir	182 litres (48 US gallons) capacity. Exterior oil level gauge.
Oil cooler	Thermostatically controlled, electric fan motor.

HOIST SPECIFICATIONS

Power up and down, equal speed, planetary reduction with integral automatic spring-applied multi-disc brake, over lower limit switch.

Main hoist

Maximum single line speed

Bottom layer	71 m/min (233 fpm)
Intermediate layer	77 m/min (253 fpm)
Top layer	83 m/min (273 fpm)

Maximum single line pull

Bottom layer	3300 kg (7275 lb)
Intermediate layer	3070 kg (6768 lb)
Top layer	2840 kg (6261 lb)

Rope supplied 70 m × 13 mm diameter (230 ft × ½ in).

*Indicates optional item.